

PCM-3718 Series

**PC/104 12-bit DAS Module
with Programmable Gain**

User Manual

Copyright

This documentation and the software included with this product are copyrighted 2009 by Advantech Co., Ltd. All rights are reserved. Advantech Co., Ltd. reserves the right to make improvements in the products described in this manual at any time without notice.

No part of this manual may be reproduced, copied, translated or transmitted in any form or by any means without the prior written permission of Advantech Co., Ltd. Information provided in this manual is intended to be accurate and reliable. However, Advantech Co., Ltd. assumes no responsibility for its use, nor for any infringements of the rights of third parties which may result from its use.

Acknowledgments

PC-LabCard and ADAQView are registered trademarks of Advantech Co., Ltd. All other brands, trademarks, or products listed are tradenames or trademarks of their respective companies.

This Manual Covers the Following Models

- PCM-3718H 12-bit multifunction module with programmable gain
- PCM-3718HG PCM-3718 with high gain
- PCM-3718HO PCM-3718 with analog output

CE Notification

The products of the PCM-3718 Series, developed by Advantech Co., Ltd., have all passed the CE test for environmental specifications when shielded cables are used for external wiring. We recommend the use of shielded cables. This kind of cable is available from Advantech.

Part No.2003371833

6th Edition

Printed in Taiwan

October 2009

Product Warranty (2 years)

Advantech warrants to you, the original purchaser, that each of its products will be free from defects in materials and workmanship for two years from the date of purchase.

This warranty does not apply to any products which have been repaired or altered by persons other than repair personnel authorized by Advantech, or which have been subject to misuse, abuse, accident or improper installation. Advantech assumes no liability under the terms of this warranty as a consequence of such events.

Because of Advantech's high quality-control standards and rigorous testing, most of our customers never need to use our repair service. If an Advantech product is defective, it will be repaired or replaced at no charge during the warranty period. For out-of-warranty repairs, you will be billed according to the cost of replacement materials, service time and freight. Please consult your dealer for more details.

If you think you have a defective product, follow these steps:

1. Collect all the information about the problem encountered. (For example, CPU speed, Advantech products used, other hardware and software used, etc.) Note anything abnormal and list any onscreen messages you get when the problem occurs.
2. Call your dealer and describe the problem. Please have your manual, product, and any helpful information readily available.
3. If your product is diagnosed as defective, obtain an RMA (return merchandize authorization) number from your dealer. This allows us to process your return more quickly.
4. Carefully pack the defective product, a fully-completed Repair and Replacement Order Card and a photocopy proof of purchase date (such as your sales receipt) in a shippable container. A product returned without proof of the purchase date is not eligible for warranty service.
5. Write the RMA number visibly on the outside of the package and ship it prepaid to your dealer.

Technical Support and Assistance

- Step 1. Visit the Advantech web site at **www.advantech.com/support** where you can find the latest information about the product.
- Step 2. Contact your distributor, sales representative, or Advantech's customer service center for technical support if you need additional assistance. Please have the following information ready before you call:
 - Product name and serial number
 - Description of your peripheral attachments
 - Description of your software (operating system, version, application software, etc.)
 - A complete description of the problem
 - The exact wording of any error messages

Packing List

Before setting up the system, check that the items listed below are included and in good condition. If any item does not accord with the table, please contact your dealer immediately.

- 1x PCM-3718 series card
- 1x Companion CD-ROM (DLL driver included)
- 1x User Manual (this manual)
- 1 x Counter Cable (P/N:1700001437) (PCM-3718HO only)

Safety Precaution - Static Electricity

Follow these simple precautions to protect yourself from harm and the products from damage.

1. To avoid electrical shock, always disconnect the power from your PC chassis before you work on it. Don't touch any components on the CPU card or other cards while the PC is on.

Disconnect power before making any configuration changes. The sudden rush of power as you connect a jumper or install a card may damage sensitive electronic components.

Contents

Chapter 1	General Information	2
1.1	Introduction	2
1.2	Features.....	2
1.3	Specifications.....	3
1.3.1	Analog Input	3
1.3.2	Analog Output (PCM-3718HO only)	4
1.3.3	Digital Input and Output	5
1.3.4	Programmable Pacer	5
1.3.5	General	5
1.4	Locating Components.....	6
Figure 1.1:	Connectors, Switches and VR Locations	6
1.5	Daughterboards.....	8
1.6	Software Support	9
1.7	Block Diagram.....	10
Chapter 2	Installation	12
2.1	Initial Inspection	12
2.2	Switch and Jumper Settings.....	13
2.2.1	Base Address Selection (SW1)	13
Table 2.1:	Module I/O Addresses (SW1)	13
Table 2.2:	PC bus Address Control	13
2.2.2	DMA Channel and Timer Clock Selection (JP1)	14
2.2.3	Channel Configuration, S. E. or diff. (JP2)	14
2.2.4	External Input or D I/O Selection (JP3)	15
2.2.5	Set P1 pin 19, 20 to AGND (JP4) (PCM-3718HO)	16
2.2.6	Enable/Disable FIFO Selection (JP6) (PCM-3718HO only) ..	16
2.2.7	FIFO IRQ Address Selection (JP9) (PCM-3718HO only)	17
2.2.8	D/A Range Selection: 5/10V (JP10) (PCM-3718HO only) ...	17
2.2.9	Internal or External D/A Reference Voltage (JP11) (PCM-3718HO only)	17
2.3	Connector Pin Assignments.....	18
2.3.1	Counter Cable	20
Figure 2.1:	Pin Assignment of Counter Cable	20
Table 2.3:	Mapping Table for DB9/2 x3 Pin Header Cable ..	20
2.4	Software Installation.....	20

2.5	Hardware Installation	21
Chapter 3	Signal Connections	24
3.1	Analog Output Connection (PCM-3718HO).....	24
3.2	Analog Input Signal Connections.....	25
3.2.1	Single-ended Channel Connections	25
3.2.2	Differential Channel Connection	25
3.3	Expanding Analog Inputs	27
3.4	Digital Signal Connections.....	28
Chapter 4	Register Structure and Format.....	30
	Table 4.1: I/O Port Address Assignments	30
4.1	A/D Data Registers - BASE+0/1	31
4.2	Software A/D Trigger - BASE+0	31
4.3	A/D Range Control - BASE+1	32
4.4	MUX Scan Register -BASE+2.....	34
4.5	Digital I/O Registers - BASE+3/11	35
4.6	D/A Output — BASE+04/05H (PCM-3718HO only)	36
	Table 4.2: Register for D/A Output Data	36
4.7	FIFO Interrupt Control - (PCM-3718HO only).....	37
	Table 4.3: Register for FIFO Interrupt Control	37
4.8	A/D Status Register - BASE+8	37
4.9	Control Register - BASE+9.....	39
4.10	Pacer Enable Register - BASE+10.....	40
4.11	Programmable Pacer Reg. - BASE+12/13/14/15	40
4.12	A/D data and channel from FIFO - BASE + 17/18H (PCM-3718HO only).....	41
	Table 4.4: Register for A/D Data and Channel from FIFO ..	41
4.13	FIFO status - BASE+19H (PCM-3718HO only)	42
	Table 4.5: Register for FIFO Status	42
4.14	FIFO Clear - BASE+19H	42
	Table 4.6: Register for FIFO Clear	42
Chapter 5	A/D Conversion	44
5.1	A/D Data Format and Status Register	44
5.2	Input Range Selection.....	45

5.3	MUX Setting.....	45
5.4	Trigger Mode.....	46
5.5	A/D Data Transfer	47
5.6	How to Make an A/D Conversion.....	48
Chapter 6	Digital Input/Output	50
Chapter 7	Programmable Pacer	52
7.1	The Intel 8254.....	52
7.2	Counter Read/write and Control Register	53
7.3	Counter Operating Modes	56
7.4	Counter Operations.....	58
7.5	Counter Applications.....	59
Chapter 8	DMA Operation.....	62
8.1	Introduction to the 8237 DMA Controller.....	62
8.2	Using DMA Transfer with PCM-3718 Cards.....	63
Chapter 9	Calibration.....	66
9.1	VR Assignment.....	66
9.2	D/A, A/D Calibration	67
9.2.1	D/A Calibration Procedure	67
9.2.2	A/D Calibration Procedures	67
Appendix A	Software Driver User Note	70

CHAPTER 1

General Information

This chapter introduces the PCM-3718 Series and provides detailed specifications.

Chapter 1 General Information

1.1 Introduction

The PCM-3718 Series consist of high performance multifunction data acquisition modules that attach to the PC/104 connector on your CPU card or PC/104 module. It offers 12-bit A/D conversion and digital input/output.

The automatic channel-scanning circuitry and the onboard SRAM let you perform multiple channel A/D conversions with DMA and individual channel gains.

These PC/104 modules are fully software compatible with the popular PCL-818H and PCL-818HG. This puts rich software support and a wide variety of external signal conditioning boards at your disposal.

The PCM-3718 Series is excellent for data acquisition, process control, automatic testing and factory automation.

1.2 Features

- 16 single-ended or 8 differential analog inputs, jumper selectable
- 12-bit A/D converter, up to 100 kHz sampling rate with DMA transfer
- Software programmable gain value for each analog input channel
- Software selectable input range for each analog input channel
- Two 8-bit digital input/output channels, TTL compatible
- Flexible triggering options: software trigger, programmable pacer trigger and external pulse trigger
- Data transfer by program control, interrupt handler routine or DMA
- 1k FIFO on AI (PCM-3718HO)
- 12-bit D/A Converter (PCM-3718HO)
- 16-bit programmable counter/timer

1.3 Specifications

1.3.1 Analog Input

- **Channels:** 16 single-ended or 8 differential, jumper selectable
- **Resolution:** 12 bits
- **FIFO:** 1k (PCM-3718HO only)
- **Input Range:** (software programmable, VDC)

PCM-3718H and PCM-3718HO

Bipolar: ± 10 , ± 5 , ± 2.5 , ± 1.25 , ± 0.625

Unipolar: 0 ~ 10, 0 ~ 5, 0 ~ 2.5, 0 ~ 1.25

PCM-3718HG

Bipolar: ± 10 , ± 5 , ± 1 , ± 0.5 , ± 0.1 , ± 0.05 , ± 0.01 , ± 0.005

Unipolar: 0 ~ 10, 0 ~ 1, 0 ~ 0.1, 0 ~ 0.01

- **Max. Sampling Rate: 100 KHz* (DMA transfer)**

*80 kHz on P4-based (or upper) system

* The DMA mode AI sampling can only be operated on the ISA bus of a P3* motherboard. For platforms that are using P4* motherboard or above, the DMA mode AI sampling of Advantech's ISA cards may decrease, or not work at all.

P3 = Pentium III microprocessor from Intel

P4 = Pentium IV microprocessor from Intel

We recommend the customer use Intel P3-installed PC to work with Advantech's ISA cards for high-speed DMA AI sampling.

- **Maximum Data Throughput**

PCM-3718H and PCM-3718HO: 100 kHz

PCM-3718HG: (variable, depending on PGIA settling time)

<i>Gain</i>	<i>Speed</i>
0.5, 1	100 kHz
5,10	35 kHz
50,100	7 kHz
500,1000	770 Hz

- **Accuracy:** (depending on gain values)

PCM-3718H and PCM-3718HO

<i>Gain</i>	<i>Accuracy</i>
0.5,1	0.01% of FSR±1 LSB
2,4	0.02% of FSR±1 LSB
8	0.04% of FSR±1 LSB

PCM-3718HG

<i>Gain</i>	<i>Accuracy</i>
0.5,1	0.01% of FSR±1 LSB
5,10	0.02% of FSR±1 LSB
50,100	0.04% of FSR±1 LSB for differential mode
500,1000	0.08% of FSR±1 LSB for differential mode

- Differential nonlinearity error: ±1 LSB
- **Input Impedance:** 1 GW
- **Trigger Mode:** Software, pacer or external trigger
- **External Trigger:** TTL compatible

1.3.2 Analog Output (PCM-3718HO only)

- **Channels:** 1
- **Resolution:** 12-bit
- **Output Range:**
Internal 0~+5V , 0~+10V
External -10~+10V
- **Accuracy INLE:** ±0.5 LSB (monotonic)
- **Settling Time:** 26 μs (to ±1/2 LSB of FSR)
- **Gain Error:** Adjustable to zero
- **Slew Rate:** 10 V/μs
- **Drift:** 40 ppm/°C
- **Driving Capability:** 3 mA
- **Max. Update Rate:** 100 k samples/s
- **Output Impedance:** 810 mW (min.)

1.3.3 Digital Input and Output

- **Channels:** Two 8-bit
- **Level:** TTL compatible
- **Input Voltage:**
 - Logic 0: 0.8 V max.
 - Logic 1: 2.0 V min.
- **Output Voltage:**
 - Logic 0: 0.33 V max. @ 6 mA (sink)
 - Logic 1: 3.84 V min. @ 6 mA (source)

1.3.4 Programmable Pacer

- **Device:** Intel 8254 or equivalent
- **Counters:** 3 channels, 16-bit.
Counter 1 and Counter 2 are permanently configured as a 32-bit programmable pacer. Counter 0 is free for your applications. (PCM-3718HO only)
- **Time Base:** (for Counter 1's clock input)
10 MHz or 1 MHz, jumper selectable.

1.3.5 General

- **Power Consumption:** +5V_{DC} @ 180mA (Typical)
+5V_{DC} @ 400mA (Max.)
- **Digital I/O Connector:** 20-pin post headers for I/O connection.
- **Analog Input Connector:** 20-pin post headers for I/O connection.
- **Operating Temperature:** 0 ~ 60° C (refer to IEC 68-2-1, 2)
- **Storage Temperature:** -20 ~ 70° C
- **Operating Humidity:** 5 to 95% non-condensing (refer to IEC 68-2-3)
- **MTBF:** Over 235,346 hrs @ 25°C, grounded, fixed environment

1.4 Locating Components

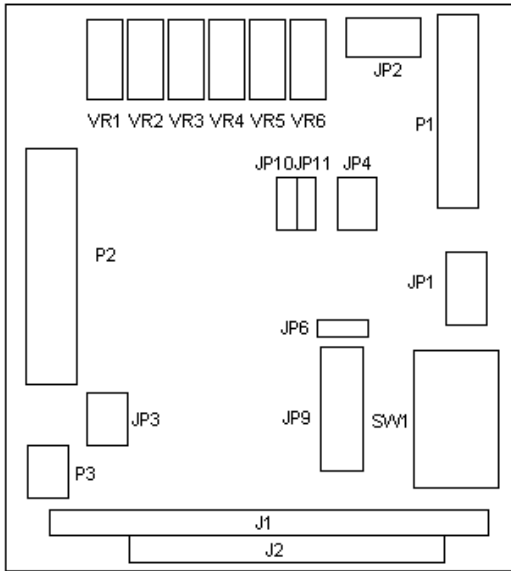

Figure 1.1: Connectors, Switches and VR Locations

Label	Function
J1	PC-bus connector
J2	Reserved (PCM-3718HO only)
JP1	DMA level (1 or 3) and time base (1MHz or 10MHz)
JP2	Differential or single-ended inputs
JP3	DIO0 or external input
JP4	Set P1 pin 19, 20 to AGND or D/A pin use (PCM-3718HO only)
JP6	FIFO enable/disable selection (PCM-3718HO only)
JP9	FIFO IRQ address selection (PCM-3718HO only)
JP10	D/A range select selection (5 or 10V) (PCM-3718HO only)
JP11	D/A reference voltage as internal or external (PCM-3718HO only)
P1	Analog input
P2	Digital input/output connector
P3	Counter (PCM-3718HO only)
SW1	Base address
VR1	A/D full scale
VR2	A/D bipolar offset
VR3	A/D unipolar offset
VR4	PGA offset (PCM-3718HG only)
VR5	D/A full scale adjustment (PCM-3718HO only)
VR6	D/A offset (PCM-3718HO only)

1.5 Daughterboards

We offer a wide variety of optional daughterboards to help you get the most from your PCM-3718 card. You will need the PCLD-780 or PCLD-880 Screw-terminal Board, or the PCLD-8115 Wiring Terminal Board to make connections.

PCLD-789D Amplifier/Multiplexer Board

This analog input-signal conditioning board multiplexes 16 differential inputs to one A/D input channel. A high-grade instrumentation amplifier provides switch selectable gains of 1, 2, 10, 50, 100, 200 or 1000.

PCLD-788 Relay Multiplexer Board

This board multiplexes up to 16 differential inputs to one analog output channel. It offers isolated break-before-make high voltage switching and a CJC circuit for thermocouple measurement.

PCLD-786 SSR I/O Module Carrier Board

This board holds eight opto-isolated solid state relay modules and provides an additional eight outputs to drive external applications.

PCLD-785B and PCLD-885 Relay Output Boards

These boards let you control relays through the PCM-3718's 16-bit digital output channels. PCLD-785B provides 24 SPDT relays, while the PCLD-885 provides 16 SPDT power relays.

PCLD-782B Isolated D/I Board

This board provides 24 opto-isolated digital inputs for connecting to PCM-3718's digital input channels.

1.6 Software Support

The PCM-3718 Series comes with a powerful and easy-to-use software driver. This driver makes application programming much easier, especially when you use sophisticated features like interrupt or DMA data transfer.

For creating a high performance Human Machine Interface (HMI), you may need other supporting software beside our included driver for the PCM-3718 cards. Please consult your Advantech representative for appropriate software packages. Some suggestions are listed below.

ADAQView

ADAQView is a Windows-based data acquisition, control, analysis and presentation development software package. In addition to typical Human Machine Interface (HMI) functions, ADAQView features a Visual Basic programming environment, and it provides numerous graphical control and display icons to assist you in developing HMIs.

ActiveDAQ

ActiveDAQ is a collection of add-on ActiveX controls which provides an easy-to-use property sheet interface for configuring analog/digital input/output, counter/frequency, high-speed data acquisition and controls. You can use ActiveX control in Visual Basic, Delphi and Visual C++ development environments for Windows 98/2000/XP.

LabVIEW Driver

The Advantech LabVIEW driver supports National Instruments LabVIEW 7.1 and runs in Microsoft Windows 98/2000/XP.

1.7 Block Diagram

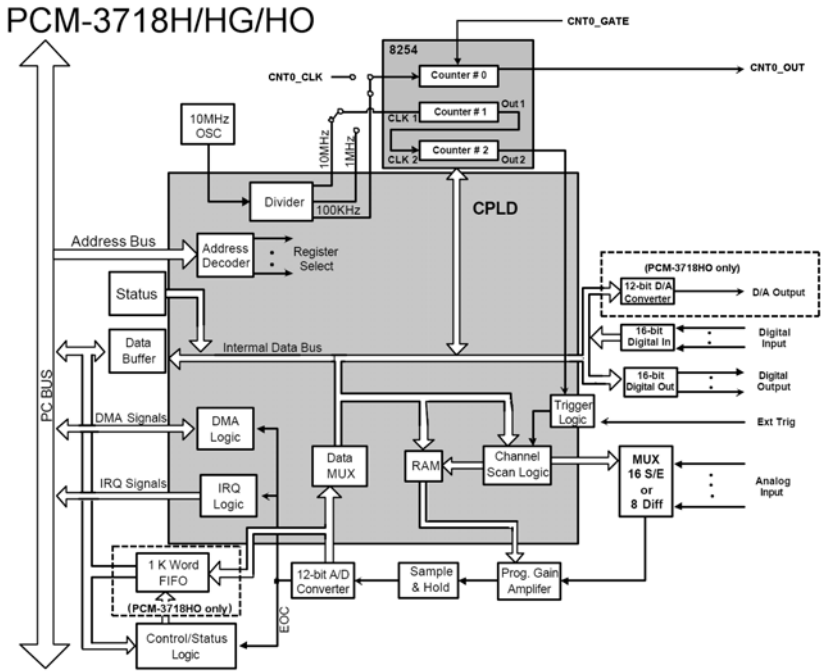

Note CNT0-OUT is only for PCM-3718HO

Installation

This chapter explains how to install PCM-3718 cards, and how to configure its switch and jumper settings.

Chapter 2 Installation

2.1 Initial Inspection

All cards in the PCM-3718 Series are carefully inspected mechanically and electrically before shipment. It should be free of marks and scratches and in perfect order when received.

As you unpack the PCM-3718 card, check for signs of shipping damages (damaged box, scratches, dents, etc.). If it is damaged or fails to meet specifications, notify our service department or your local sales representative immediately. We will then make arrangement to repair or replace the unit for you.

Discharge any static electricity on your body before touching the board by touching the back of the system unit (grounded metal).

Also keep from materials of static electricity such as plastic, vinyl and styrofoam.

Remove the PCM-3718 card from its protective packaging by grasping the rear metal panel. Handle the module only by its edges to avoid static electricity which could damage its integrated circuits. Keep the anti-static packaging material for storage and protection when you have to remove the module from its connector.

2.2 Switch and Jumper Settings

Ease-of-use was a primary design goal when we designed the PCM-3718 Series. This module has one function switch and seven jumper settings. The following sections tell you how to configure the module. You may want to refer to the figure on page 5 to easier locate the jumpers and switches.

2.2.1 Base Address Selection (SW1)

You control PCM-3718's operation by reading or writing data to the PC's I/O (input/output) port addresses. PCM-3718 requires 16 consecutive address locations. The switch SW1 sets the module's base (beginning) address. Valid base addresses range from Hex 000 to Hex 3F0. Other devices in your system can use some of these addresses.

PCM-3718's base address was set to Hex 300 at the factory. If you need to adjust it to other address ranges, set SW1 by referring to table 2.1

Table 2.1: Module I/O Addresses (SW1)

Range (hex)	Switch position					
	1	2	3	4	5	6
000 - 00F	Off	Off	Off	Off	Off	Off
010 - 01F	Off	Off	Off	Off	Off	On
:						
200 - 20F	On	Off	Off	Off	Off	Off
210 - 21F	On	Off	Off	Off	Off	On
:						
*300 - 30F	On	On	Off	Off	Off	Off
:						
3F0 - 3FF	On	On	On	On	On	On

* = default

Note Switches 1-6 on SW1 control the PC bus address

Table 2.2: PC bus Address Control

Switch	1	2	3	4	5	6
Line	A9	A8	A7	A6	A5	A4

2.2.2 DMA Channel and Timer Clock Selection (JP1)

The PCM-3718 cards support DMA data transfer. The bottom pins of JP1 provide selection of DMA channel 1 or 3, as shown in the following figure.



The upper three pins of JP1 control the input clock frequency for the 8254 programmable clock/timer of the module.

You have two choices: 10 MHz or 1 MHz. This lets you generate pacer output frequencies from 2.5 MHz to 0.00023 Hz (71 minutes/pulse).

The following equation gives the pacer rate:

$$\text{Pacer rate} = \text{Fclk} / (\text{Div1} * \text{Div2})$$

(Fclk, 1 MHz or 10 MHz, is set by JP1 as illustrated below. Div1 and Div2 are dividers set in counter 1 and counter 2 in the Intel 8254 counter. See page 51 for more information on the counter/timer applications).

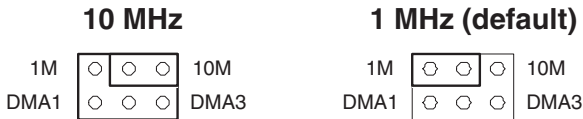

2.2.3 Channel Configuration, S. E. or diff. (JP2)

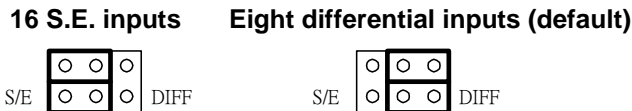

The PCM-3718 cards offer 16 single-ended or eight differential analog input channels. Jumper JP2 sets the analog input channels as 16 single-ended or 8 differential inputs as shown below:



2.2.4 External Input or D I/O Selection (JP3)



PCM-3718H and PCM-3718HG

Jumper JP3 controls the selection of signals on pin 1 at connector P2. Pin 1 on connector P2 can be connected to digital I/O line 0 or to an External Clock as shown below.

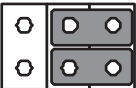

External trigger input	EXT		DIO 0
Digital I/O Line DIO 0 (default)	EXT		DIO 0

PCM-3718HO

For PCM-3718HO, you can control signals on both pin 1 and pin 2 of connector P2. Pin 1 can connect to digital I/O line 0 (DIO 0), and pin 2 can connect to digital I/O line 2 (DIO 2). This is the default setting of JP3.

Digital I/O Line DIO 0 and DIO 2 (default)	GO		DIO 2
	EXT		DIO 0

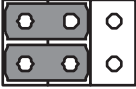
Pin 1 can also be set to external A/D trigger source (EXT), and pin 2 can be connected to counter gate 0. (G0).

External trigger input & counter gate 0.	GO		DIO 2
	EXT		DIO 0

Note When the jumper setting is set to GO, the functionality is the same as CNT0_GATE of P3.

When the jumper setting is set to EXT, the functionality is the same as EXT_TRIG of P3.

2.2.5 Set P1 pin 19, 20 to AGND (JP4) (PCM-3718HO)

You can use pin19 and pin20 on connector P1 for connection to AGND or D/A output.

Pin19 is used to set AGND or D/A output (1, 3, 5)

Pin20 is used to set AGND or D/A voltage reference (2, 4, 6)

Pin19 and Pin20 will be set to AGND

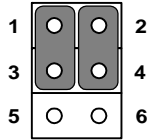

Pin19 will be set to D/A output

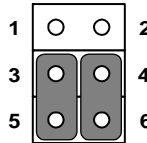

Pin20 will be set to D/A reference

2.2.6 Enable/Disable FIFO Selection (JP6) (PCM-3718HO only)

You can use JP6 to enable or disable the FIFO function.

Set jumper on pin(1-2) to enable FIFO. (As shown below)

Set jumper on pin(2-3) to disable FIFO.

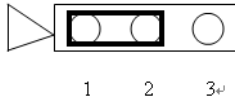

2.2.7 FIFO IRQ Address Selection (JP9) (PCM-3718HO only)

You can set the FIFO IRQ address with JP9.

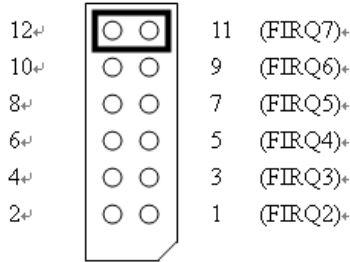

2.2.8 D/A Range Selection: 5/10V (JP10) (PCM-3718HO only)

JP10 lets users select the D/A output range.

Set the jumper on pin 1 and 3, to make the D/A range 0 ~ 10 V.

Set the jumper on pin 3 and 5, to make the D/A range 0 ~ 5 V.

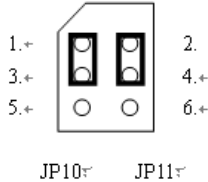

2.2.9 Internal or External D/A Reference Voltage (JP11) (PCM-3718HO only)

JP11 lets users select the D/A reference voltage as internal or external.

Set Jumper on pin 2 and 4, to make the reference voltage internal.

Set Jumper on pin 4 and 6, to make the reference voltage external.

2.3 Connector Pin Assignments

PCM-3718 cards have two onboard 20-pin flat-cable connectors (insulation displacement, mass termination).

The figure on page 5 shows locations of both connectors, while the next page shows pin assignments for P1, P2 and P3.

Refer to the table below for descriptions for abbreviations on the pins.

Abbreviations	Description
A/D S	Analog input (single-ended)
A/D H	Analog input high (differential)
A/D L	Analog input low (differential)
A.GND	Analog ground
DIO	Digital input/output
D.GND	Digital and power supply ground
PCR_TRIG	Pacer Clock Output. This pin pulses once for each pacer clock when turned on. If A/D conversion is in the pacer trigger mode, this signal can be used as a synchronous signal for other applications. A low - to- high edge triggers A/D conversion to start.
CNT0_Gate	Counter 0 Gate
EXT_TRIG	A/D External Trigger. This pin is external trigger signal input for the A/D conversion. A low-to-high edge triggers A/D conversion to get one sample.
CNT0_OUT	Counter 0 Output
CNT0_CLK	Counter 0 Clock

Connector P1 - Analog Input, Single-ended Operation

A/D S0	1	2	A/D S8
A/D S1	3	4	A/D S9
A/D S2	5	6	A/D S10
A/D S3	7	8	A/D S11
A/D S4	9	10	A/D S12
A/D S5	11	12	A/D S13
A/D S6	13	14	A/D S14
A/D S7	15	16	A/D S15
A.GND	17	18	A.GND
A.GND	19	20	A.GND

Connector P1 - Analog Input, Differential-ended

A/D H0	1	2	A/D L0
A/D H1	3	4	A/D L1
A/D H2	5	6	A/D L2
A/D H3	7	8	A/D L3
A/D H4	9	10	A/D L4
A/D H5	11	12	A/D L5
A/D H6	13	14	A/D L6
A/D H7	15	16	A/D L7
A.GND	17	18	A.GND
A.GND	19	20	A.GND

Connector P2 - Digital Input /Output

DIO 0	1	2	DIO 1
DIO 2	3	4	DIO 3
DIO 4	5	6	DIO 5
DIO 6	7	8	DIO 7
DIO 8	9	10	DIO 9
DIO 10	11	12	DIO 11
DIO 12	13	14	DIO 13
DIO 14	15	16	DIO 15
D.GND	17	18	D.GND
+5V	19	20	+12V

Connector P3 - Counter / Timer (PCM-3718HO only)

PCR_TRIG	1	2	GND
CNT0_GATE	3	4	CNT0_OUT
EXT_TRIG	5	6	CNT0_CLK

2.3.1 Counter Cable

PCM-3718 is equipped with a counter function that gives you more flexibility in data acquisition applications. The following shows the pin assignment and the pin definition of the cable.

PCR_TRIG	1	2	GND
CNT0_GATE	3	4	CNT0_OUT
EXT_TRIG	5	6	CNT0_CLK

Figure 2.1: Pin Assignment of Counter Cable

Table 2.3: Mapping Table for DB9/2 x3 Pin Header Cable

DB9		Pin Header	
1	PCR_TRIG	1	PCR_TRIG
2	GND	2	GND
3	CNT0_GATE	3	CNT0_GATE
4	CNT0_OUT	4	CNT0_OUT
5	EXT_TRIG	5	EXT_TRIG
6	CNT0_CLK	6	CNT0_CLK
7	Disconnect	-	
8	Disconnect	-	
9	Disconnect	-	

2.4 Software Installation

The PCM-3718 cards include a CD-ROM with utility software. The CD-ROM contains:

1. A comprehensive I/O driver for A/D, D/A, and digital I/O applications. This driver lets you use standard functions, written in common programming languages, to operate the PCM-3718 card. You do not need to perform complex register programming. The driver supports the following languages: Microsoft Visual Basic, Visual C++, Borland C++, C++ Builder and Delphi. Please refer to the Software Driver's User Manual for more information.
2. Demonstration programs
3. A calibration program
4. A test program

2.5 Hardware Installation

Warning! TURN OFF your PC power supply whenever you install or remove the PCM-3718H/3718HG or connect and disconnect cables.

Installing the module

1. Turn the PC's power off. Turn off the power of any peripheral devices such as printers and monitors.
2. Disconnect the power cord and any other cables from the back of the computer.
3. Remove the system unit cover (see the user's guide for your chassis if necessary).
4. Remove the CPU card from the chassis (if necessary) to gain access to the card's PC/104 connector.
5. Connect connector J1 of the PCM-3718 card to the PC/104 connector. Carefully align the pins with the PC/104 connector. Slide the module into the connector. The module pins may not slide all the way into the connector; do not force the pins into place, or the module may be damaged.
6. Fasten the module to the CPU card by using the included brass screw. Screw the brass spacer into the threaded hole on the CPU card. Do not tighten too much, or the threads may be damaged.
7. Attach any accessories to the PCM-3718 card using 20 pin cables.
8. Reinstall the CPU card and replace the system unit cover. Reconnect the cables you removed in step 2. Plug in and turn on the power.

This completes the hardware installation. Install the software driver as described in the following section.

CHAPTER 3

Signal Connections

This chapter provides information on signal connections for different types of data acquisition applications.

Chapter 3 Signal Connections

3.1 Analog Output Connection (PCM-3718HO)

PCM-3718HO provides one D/A output channel. You can use the internal precision -5 V or -10 V reference to generate 0 to +5 V or 0 to +10 V D/A output. Use an external reference for other D/A output ranges. The maximum reference input voltage is ± 10 V and maximum output scaling is ± 10 V. The loading current for D/A outputs should not exceed 5 mA.

Connector P1 provides D/A signals. Important D/A signal connections such as input reference, D/A outputs and analog ground appear below.

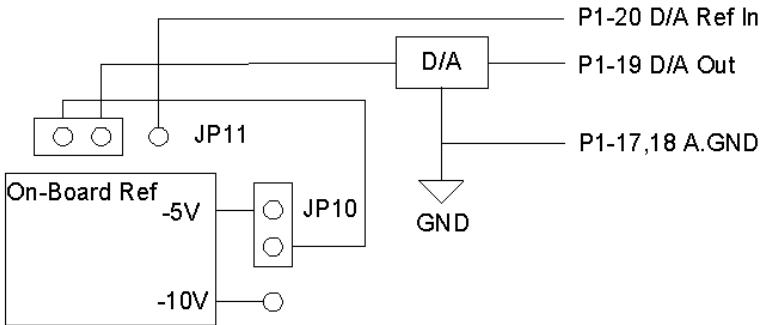

3.2 Analog Input Signal Connections

The PCM-3718 cards support either 16 single-ended or eight differential analog inputs. Jumper JP3 selects the input channel configuration (See 2.2.3). The major difference between single-ended and differential input connections is the number of signal wires per input channel.

3.2.1 Single-ended Channel Connections

Single-ended connections use only one signal wire per channel. The voltage on the line refers to the common ground on the card. A signal source without a local ground is called a “floating” source. It is fairly simple to connect a signal-ended channel to a floating signal source. A standard wiring diagram looks like this.

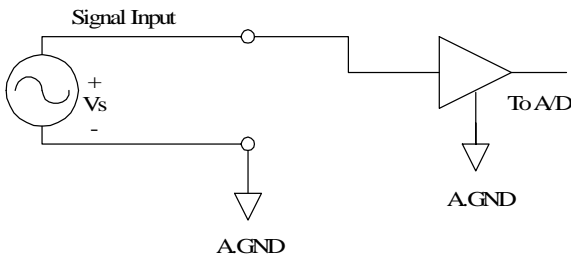

3.2.2 Differential Channel Connection

The differential input configuration uses two signal wires per channel. The card measures the voltage difference between these two wires, the HIGH wire and the LOW wire. If the signal source has no connection to local ground, it is called a “floating” source. A connection must exist between LOW and ground to define a common reference point for floating signal sources. To measure a floating source connect the input channel as shown below.

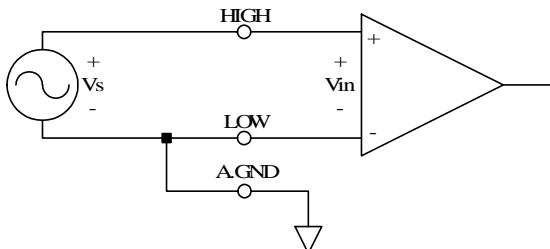

If the signal source has one side connected to a local ground, the signal source ground and PCM-3718's ground will not be at exactly the same voltage, as they are connected through the ground return of the equipment and building wiring. The difference between the ground voltages form a common-mode voltage.

To avoid the ground loop noise effect caused by common-mode voltages, connect the signal ground to the LOW input. Do not connect the LOW input to the PCM-3718's ground directly. In some cases you may also need a wire connection between the PCM-3718's ground and the signal source ground for better grounding. The following two diagrams show correct and incorrect connections for a differential input with local ground.

Correct Connection

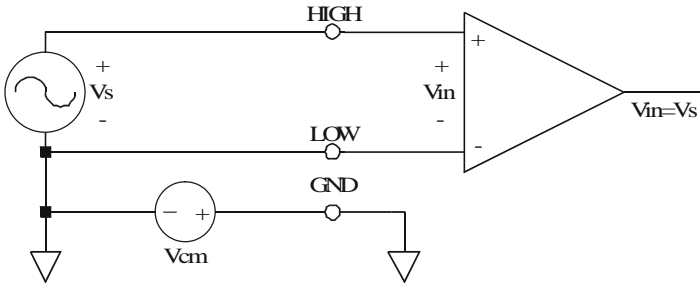

Incorrect Connection

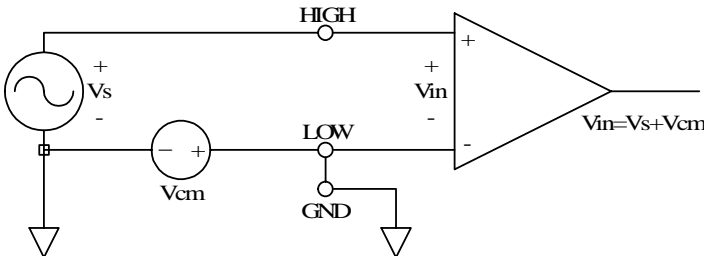

3.3 Expanding Analog Inputs

You can expand any or all of PCM-3718's A/D input channels by using multiplexing daughterboards. Most daughterboards are connected directly to the module's 20-pin connectors. You may require the PCLD-8115 Screw-terminal Board for connections.

The PCLD-789 Amplifier and Multiplexer multiplexes 16 differential inputs to one A/D input channel. You can cascade up to eight PCLD-789s to the PCM-3718H/3718HG for a total of 128 channels.

The PCLD-8115 Screw-terminal Board makes wiring connections easy. It provides 20-pin flat cable connectors and a CJC (Cold Junction Compensation) circuit which lets you directly measure thermocouples. You can handle all types of thermocouples with software compensation and linearization.

Special circuit pads on the PCLD-8115 accommodate passive signal conditioning components. You can easily implement a low-pass filter, attenuator or current shunt by adding resistors and capacitors.

3.4 Digital Signal Connections

The PCM-3718 cards have two 8-bit digital input/output channels. The digital I/O levels are TTL compatible. The following figure shows connections of digital signals with other TTL devices:

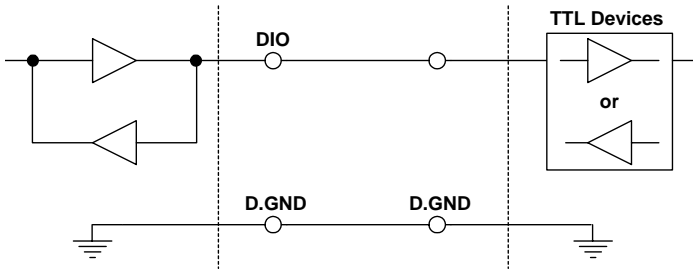

To receive an OPEN/SHORT signal from a switch or relay, add a pull-up resistor to ensure that the input is held at a high level when the contacts are open. See the figure below:

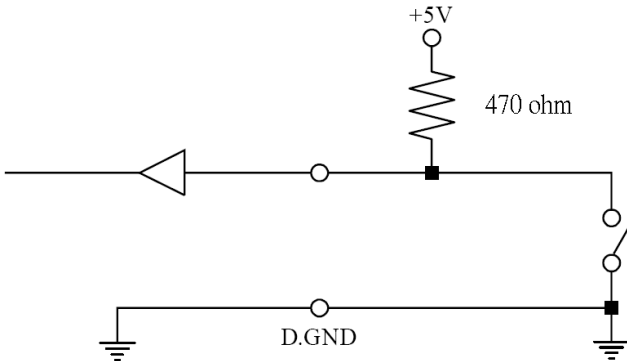

CHAPTER 4

Register Structure and Format

This chapter gives detailed information on the layout and function of each of the card's registers.

Chapter 4 Register Structure and Format

The key to programming the PCM-3718 cards is to understand the function of the 16 registers. The PCM-3718 cards require 19 consecutive addresses in the PC's I/O space. Each address corresponds to a card register. The address of each register is specified as an offset from the card's base address. For example, BASE+0 is the card's base address and BASE+7 is the base address plus seven bytes. If the card's base address is 300h, the register's address is 307h. The following sections give detailed information on the layout and function of each of the card's registers.

I/O Port Address Map

The following table shows the function of each register or driver and its address relative to the base address of the module.

Table 4.1: I/O Port Address Assignments

Address	Read	Write
BASE+0	A/D low byte & channel	Software A/D trigger
BASE+1	A/D high byte	A/D range control
BASE+2	MUX scan	MUX scan channel & range control pointer
BASE+3	DIO low byte (DIO 0-7)	DIO low byte (DIO 0-7)
BASE+4	N/A	D/A output data (PCM-3718HO only)
BASE+5	N/A	D/A output data (PCM-3718HO only)
BASE+6	N/A	FIFO interrupt control (PCM-3718HO only)
BASE+7	N/A	N/A
BASE+8	Status	Clear interrupt request
BASE+9	Control	Control
BASE+10	N/A	Counter enable
BASE+11	DIO high byte (DIO 8-15)	DIO high byte (DIO 8-15)
BASE+12	Counter 0	Counter 0
BASE+13	Counter 1	Counter 1
BASE+14	Counter 2	Counter 2
BASE+15	N/A	Counter control
BASE+17	N/A	A/D data and channels from FIFO (PCM-3718HO only)
BASE+18	A/D data and channels from FIFO	N/A (PCM-3718HO only)
BASE+19	FIFO status	FIFO clear (PCM-3718HO only)

4.1 A/D Data Registers - BASE+0/1

Two read-only registers at BASE+0 and BASE+1 hold A/D conversion data. The 12 bits of data from the A/D conversion are stored in BASE+1 bit 7 to bit 0 and BASE+0 bit 7 to bit 4. BASE+0 bits 3 to 0 store the source A/D channel number.

BASE+0 (read only) - A/D low byte & channel number								
Bit	D7	D6	D5	D4	D3	D2	D1	D0
Value	AD3	AD2	AD1	AD0	C3	C2	C1	C0

BASE+1 (read only) - A/D high byte								
Bit	D7	D6	D5	D4	D3	D2	D1	D0
Value	AD11	AD10	AD9	AD8	AD7	AD6	AD5	AD4

AD11 to AD0 Analog to digital data. AD0 is the least significant bit (LSB) of the A/D data, and AD11 is the most significant bit (MSB)

C3 to C0 A/D channel number from which the data is derived. C3 is the MSB and C0 is the LSB

4.2 Software A/D Trigger - BASE+0

You can trigger an A/D conversion from software, the module's onboard pacer or from an external pulse. Bits 1 and 0 of register BASE+9 (shown on pages 31~32) select the trigger source. If you select software triggering, a write to the register BASE+0 with any value will trigger an A/D conversion.

4.3 A/D Range Control - BASE+1

Each A/D channel has its own individual input range, controlled by a range code stored in the onboard RAM. If you want to change the range code for a given channel, select the channel as the start channel in register BASE+2, MUX scan (described in the next section), then write the range code to bits 0 to 3 of BASE+1.

BASE+1 (write only) - A/D range control code								
Bit	D7	D6	D5	D4	D3	D2	D1	D0
Value	N/A	N/A	N/A	N/A	G3	G2	G1	G0

PCM-3718H and PCM-3718HO range code:

Input Range (V)	Unipolar/ Bipolar	Range Code			
		G3	G2	G1	G0
±5	B	0	0	0	0
±2.5	B	0	0	0	1
±1.25	B	0	0	1	0
±0.625	B	0	0	1	1
0 to 10	U	0	1	0	0
0 to 5	U	0	1	0	1
0 to 2.5	U	0	1	1	0
0 to 1.25	U	0	1	1	1
±10	B	1	0	0	0
N/A		1	0	0	1
N/A		1	0	1	0
N/A		1	0	1	1
N/A		1	1	0	0
N/A		1	1	0	1
N/A		1	1	1	0
N/A		1	1	1	1

PCM-3718HG range code:

Input Range (V)	Unipolar/ Bipolar	Range Code			
		G3	G2	G1	G0
±5	B	0	0	0	0
±0.5	B	0	0	0	1
±0.05	B	0	0	1	0
±0.005	B	0	0	1	1
0 to 10	U	0	1	0	0
0 to 1	U	0	1	0	1
0 to 0.1	U	0	1	1	0
0 to 0.01	U	0	1	1	1
±10	B	1	0	0	0
±1	B	1	0	0	1
±0.1	B	1	0	1	0
±0.01	B	1	0	1	1
N/A		1	1	0	0
N/A		1	1	0	1
N/A		1	1	1	0
N/A		1	1	1	1

4.4 MUX Scan Register -BASE+2

Read/write register BASE+2 controls multiplexer (MUX) scanning. The high nibble provides the stop scan channel number, and the low nibble provides the start scan channel number. The MUX initializes automatically to the start channel when you write to this register. Each A/D trigger sets the MUX to the next channel.

With continuous triggering, the MUX will scan from the start channel to the end channel, and then repeat the process. For example, if the start channel is 3 and the stop channel is 7, then the scan sequence is 3, 4, 5, 6, 7, 3, 4, 5, 6, 7, 3, 4 ...

BASE+2 (write) - start and stop scan channels								
Bit	D7	D6	D5	D4	D3	D2	D1	D0
Value	CH3	CH2	CH1	CH0	CL3	CL2	CL1	CL0

CH3 to CH0 Stop scan channel number

CL3 to CL0 Start scan channel number

The MUX scan register low nibble, CL3 to CL0, also acts as a pointer when you program the A/D input range (see previous section). When you set the MUX start channel to N, the range code written to the register BASE+1 is for channel N.

Programming example

This C code sets the range for channel 5 to ± 0.625 V:

```
OUTPORTB (BASE+2, 5); /* SET POINTER TO CHANNEL 5*/  
OUTPORTB (BASE+1, 3); /* RANGE CODE FOR  $\pm 0.625$ V*/
```

Note The MUX start/stop channel changes each time when you change the input range. Do not forget to reset the MUX start and stop channels to the correct values after your range setting.

4.5 Digital I/O Registers - BASE+3/11

The PCM-3718 cards offer two 8-bit digital input/output channels. These I/O channels use the input or output ports at addresses Base+3 and BASE+11.

BASE+3 (read port) -DIO low byte								
Bit	D7	D6	D5	D4	D3	D2	D1	D0
Value	DIO7	DIO6	DIO5	DIO4	DIO3	DIO2	DIO1	DIO0

BASE+3 (write port) DIO low byte								
Bit	D7	D6	D5	D4	D3	D2	D1	D0
Value	DIO7	DIO6	DIO5	DIO4	DIO3	DIO2	DIO1	DIO0

BASE+11 (read port) - DIO high byte								
Bit	D7	D6	D5	D4	D3	D2	D1	D0
Value	DIO15	DIO14	DIO13	DIO12	DIO11	DIO10	DIO9	DIO8

BASE+11 (write port) - DIO high byte								
Bit	D7	D6	D5	D4	D3	D2	D1	D0
Value	DIO15	DIO14	DIO13	DIO12	DIO11	DIO10	DIO9	DIO8

4.6 D/A Output — BASE+04/05H (PCM-3718HO only)

Write-only registers BASE+04H and BASE+05H accept data for D/A output.

PCM-3718HO provides one D/A output channel with two double-buffered 12-bit multiplying D/A converters. Write registers at addresses BASE+04H and BASE+05H hold output data. DA0 is the least significant bit (LSB) and DA11 is the most significant bit (MSB) of the D/A data.

Table 4.2: Register for D/A Output Data

Write	D/A Output Data							
Bit #	7	6	5	4	3	2	1	0
BASE+04H	DA3	DA2	DA1	DA0	X	X	X	X
BASE+05H	DA11	DA10	DA9	DA8	DA7	DA6	DA5	DA4

DA11 ~ DA0 Analog to digital data

DA0 The least significant bit (LSB) of the D/A data

DA11 The most significant bit (MSB)

When you write data to the D/A channels, write the low byte first. The low byte is temporarily held by a register in the D/A and not released to the output. After you write the high byte, the low byte and high byte are added and passed to the D/A converter. This double buffering process protects the D/A data integrity through a single step update.

PCM-3718HO provides a precise fixed internal -5 V or -10 V reference, selectable by means of jumper JP10. This reference voltage is available at connector P1 pin 20. If you use this voltage as the D/A reference input, the D/A output range is either 0 to +5 V or 0 to +10 V. You can also use an external DC or AC source as the D/A reference input. In this case, the maximum reference input voltage is ± 10 V, and the maximum D/A output ranges are 0 to +10 V or 0 to -10 V.

Connector P1 supports all D/A signal connections. Chapter 2 shows connector pin assignments, while chapter 3 has a wiring diagram for D/A signal connections.

4.7 FIFO Interrupt Control - (PCM-3718HO only)

Table 4.3: Register for FIFO Interrupt Control

Write	FIFO interrupt control							
Bit#	7	6	5	4	3	2	1	0
BASE+06H	X	X	X	X	X	X	X	FINT

FINT Enables/disables FIFO interrupt

- 0 FIFO interrupt disabled
- 1 FIFO interrupt enabled

4.8 A/D Status Register - BASE+8

Read-only register BASE+8 provides information on the A/D configuration and operation. Writing to this I/O port with any data value clears its INT bit. The other data bits do not change.

BASE+8 - A/D status								
Bit	D7	D6	D5	D4	D3	D2	D1	D0
Value	EOC	N/A	MUX	INT	CN3	CN2	CN1	CN0

EOC End of Conversion.

- 0 The A/D converter is idle, ready for the next conversion. Data from the previous conversion is available in the A/D data registers.
- 1 The A/D converter is busy, implying that the A/D conversion is in progress.

MUX Single-ended/differential channel indicator.

- 0 8 differential channels
- 1 16 single-ended channels

- INT** Data valid.
- 0 No A/D conversion has been completed since the last time the INT bit was cleared. Values in the A/D data registers are not valid data.
 - 1 The A/D conversion is completed, and converted data is ready. If the INTE bit of the control register (BASE+9) is set, an interrupt signal will be sent to the PC bus through interrupt level IRQ_n, where n is specified by bits I2, I1 and I0 of the control register. Though the A/D status register is read-only, writing to it with any value clears the INT bit.
- CN3 to CN0** When EOC = 0, these status bits contain the channel number of the next channel to be converted.

Remarks

If you trigger the A/D conversion by the onboard pacer, your software should check the INT bit, not the EOC bit, before it reads the conversion data.

EOC can equal 0 in two different situations: the conversion is completed or no conversion has been started. Your software should therefore wait for the signal INT = 1 before it reads the conversion data. It should then clear the INT bit by writing any value to the A/D status register BASE+8.

4.9 Control Register - BASE+9

Read/write register BASE+9 provides information on the PCM-3718's operating modes.

BASE+9 - Control								
Bit	D7	D6	D5	D4	D3	D2	D1	D0
Value	INTE	I2	I1	I0	X	DMAE	ST1	ST0

INTE Disable/enable PCM-3718 card's interrupt generation

0 Disables the generation of interrupts. No interrupt signal will be sent to the PC bus.

1 Enables the generation of interrupts.

If DMAE = 0, the PCM-3718 card will generate an interrupt when it completes an A/D conversion. Use this setting for interrupt-driven data transfer.

If DMAE = 1, the PCM-3718 card will generate an interrupt when it receives a T/C (terminal count) signal from the PC's DMA controller, indicating that a DMA transfer has been completed. Use this setting for DMA data transfer. The DMA transfer is stopped by the interrupt caused by the T/C signal. See DMAE below.

I2 to I0 Selects the interrupt level.

Interrupt level	INL2	INL1	INL0
N/A	0	0	0
N/A	0	0	1
IRQ2	0	1	0
IRQ3	0	1	1
IRQ4	1	0	0
IRQ5	1	0	1
IRQ6	1	1	0
IRQ7	1	1	1

Note Make sure that the IRQ level you choose is not being used by another I/O device.

- DMAE** Disable/Enable PCM-3718H/HG/HO DMA transfers.
- 0 Disables DMA transfer.
 - 1 Enables DMA transfer. Each A/D conversion initiates two successive DMA request signals. These signals cause the 8237 DMA controller to transfer two bytes of conversion data from the PCM-3718 card to memory.

Note You must program the PC's 8237 DMA controller as the DMA page register before you set DMAE to 1.

ST1 to ST0 Trigger source

Trigger Source	ST1	ST0
Software trigger	0	X
External trigger	1	0
Pacer trigger	1	1

4.10 Pacer Enable Register - BASE+10

Register BASE+10 enables or disables the PCM-3718's pacer.

- TC0** Disable/enable pacer
- 0 Pacer enabled
 - 1 Pacer disabled

4.11 Programmable Pacer Reg. - BASE+12/13/14/15

These four registers located at addresses BASE+12, BASE+13, BASE+14 and BASE+15 are used for the Intel 8254 programmable pacer. Please refer to Chapter 7 Programmable Pacer or 8254 product literature for detailed application information.

4.12 A/D data and channel from FIFO - BASE + 17/18H (PCM-3718HO only)

The PCM-3718 cards store data from A/D conversions in a 1 K word First-In-First-Out (FIFO) data buffer. Registers at BASE+17H and BASE+18H store the channel number and data. The register at BASE+19H clears the FIFO buffer and sets its empty flag (EF).

Table 4.4: Register for A/D Data and Channel from FIFO

Read	A/D data and channels from FIFO							
Bit#	7	6	5	4	3	2	1	0
BASE+17H	AD3	AD2	AD1	AD0	C3	C2	C1	C0
BASE+18H	AD11	AD10	AD9	AD8	AD7	AD6	AD5	AD4

AD11 ~ AD0

Analog to digital data

AD0 the least significant bit (LSB) of the A/D data

AD11 the most significant bit (MSB)

C3 ~ C0

A/D channel number from which the data is derived

C0 the least significant bit (LSB) of the channels

C3 the most significant bit (MSB)

4.13 FIFO status - BASE+19H (PCM-3718HO only)

The register at BASE+19H clears the FIFO buffer and sets its empty flag (EF). The FIFO status register, address BASE+19H, has flags which you can read to determine the current state of the FIFO buffer, including full flag, half- full flag, and empty flag.

Table 4.5: Register for FIFO Status

Read	FIFO status							
Bit#	7	6	5	4	3	2	1	0
BASE+19H						FF	HF	EF

EF FIFO empty flag

1 FIFO is empty

0 FIFO is not empty

HF FIFO half-full flag

1 FIFO is half- full or more than half- full

0 FIFO is less than half- full

FF FIFO full flag

1 FIFO is full

0 FIFO is not full

4.14 FIFO Clear - BASE+19H

Writing any value to BASE+19H clears all data in the FIFO and sets the empty flag (EF) to 1.

Table 4.6: Register for FIFO Clear

Write	FIFO clear							
Bit#	7	6	5	4	3	2	1	0
BASE+19H	X	X	X	X	X	X	X	X

A/D Conversion

This chapter explains how to use the PCM-3718 series' A/D conversion functions.

Chapter 5 A/D Conversion

5.1 A/D Data Format and Status Register

Since the PCM-3718 cards use 12-bit A/D conversions, a single 8-bit register will not accommodate all the data. The PCM-3718 cards therefore store A/D data in two registers located at addresses BASE+0 and BASE+1.

The A/D low byte data is stored in bits D4 to D7 (AD0 to AD3) of BASE+0 and high byte data is stored in bits D0 to D7 (AD4 to AD11) of BASE+1. The least significant bit is AD0 and the most significant bit is AD11. You can read the source channel number corresponding to the A/D data from bits D0 to D3 (C0 to C3) of BASE+0.

A/D data register format is:

BASE+0 (read only) - A/D low byte & channel number								
Bit	D7	D6	D5	D4	D3	D2	D1	D0
Value	AD3	AD2	AD1	AD0	C3	C2	C1	C0

BASE+1 (read only) - A/D high byte								
Bit	D7	D6	D5	D4	D3	D2	D1	D0
Value	AD11	AD10	AD9	AD8	AD7	AD6	AD5	AD4

The A/D status register at BASE+8 (read only) gives information on A/D configuration and operation.

A/D status register format is:

BASE+8 - A/D status								
Bit	D7	D6	D5	D4	D3	D2	D1	D0
Value	EOC	N/A	MUX	INT	CN3	CN2	CN1	CN0

Bits in this register indicate the end of conversion status, single-ended/differential input, interrupt status and the number of the channel to be converted next. Refer to page 33, A/D Status Register, for more information.

5.2 Input Range Selection

Each A/D channel has its own individual input range, controlled by a range code stored in the onboard RAM. Please refer to pages 28 and 29 on A/D Range Control, for more information.

5.3 MUX Setting

PCM-3718 cards offer 16 single-ended or eight differential analog input channels. Set jumper JP2 for the channel configuration before you set the multiplexer scan range. The MUX scan register specifies the high and low limits of the scan range.

The MUX scan register is a read/write register at address **BASE+2**. Bits D0 to D3 hold the starting channel number, and positions D4 to D7 hold the stop scan channel number. When you set the PCM-3718 card for eight differential input channels, set bits CH3 and CL3 to zero.

The MUX scan register data format is as below:

BASE+2 (write) - start and stop scan channels								
Bit	D7	D6	D5	D4	D3	D2	D1	D0
Value	CH3	CH2	CH1	CH0	CL3	CL2	CL1	CL0

If you require only one A/D input channel, you should set the high and low scan limits to the same value. If you specify a range of input channels, PCM-3718 automatically performs an A/D conversion on each channel in the range, beginning with the start channel. When it reaches the stop channel, it loops back to the start channel and continues. This looping continues until the specified number of conversions is completed. Note that writing to the MUX automatically resets to the start channel.

You can specify channel settings by writing directly to the MUX scan register. Use the MUX scan register to assign to a specified channel when you set channel input ranges (with **BASE+1**). After you set the input range, you will need to reset the MUX register for the proper start and stop channels.

5.4 Trigger Mode

You can trigger an A/D conversion from software, from the module's on-board pacer or from an external signal. Bits 1 and 0 of register BASE+9 select the trigger source.

1. If you select software triggering, write to register BASE+0 with any value to trigger an A/D conversion. High-speed A/D applications do not normally use software triggering because the triggering rate is too slow.
2. The PCM-3718's onboard Intel 8254 programmable interval timer/counter can generate periodic timing signals. Counters 1 and 2 of the Intel 8254 provide A/D converter trigger pulses with precise periods. You can select pacer output between 2.5 MHz and 71 minutes per pulse. Chapter 7 cover the details of the Intel 8254 timer/counter. Pacer triggering is ideal for interrupts and DMA data transfers, normally used in A/D applications which require higher conversion speeds.
3. You can also trigger the A/D conversion from an external signal. Wire the external signal to pin 1 on connector P2 and switch jumper JP3 to EXT. You would normally use external triggering if your application requires A/D conversions not periodically, but conditionally, e. g., to measure a voltage when a limit switch closes. You can also use a function generator to create the external trigger source. The A/D conversion starts at the rising edge of the external trigger pulse.

5.5 A/D Data Transfer

You can perform A/D data transfer by Program Control, Interrupt Routine or DMA.

1. Program controlled data transfer operates by polling the A/D status register. After the A/D conversion has been triggered, your application program checks the INT bit (data valid) of the A/D status register. When it detects that the INT bit is on (1), it sends the A/D data to the PC's memory using DMA. Reset the INT bit (by writing to register BASE+8 with any value) after you transfer the A/D data.

When you use software triggering, you can check either the INT or EOC bits for data validity. Since you use the program to trigger the A/D conversion, you do not need to poll the INT bit to see if the conversion has occurred. It is easier to use the EOC bit, because you do not need to clear it after you transfer the data.

2. With interrupt data transfer, you write an interrupt routine handler program, which transfers data from the module's A/D data registers to a previously defined memory segment in the PC. At the end of each conversion, the EOC signal generates an interrupt, and the interrupt handler routine performs the transfer. You must specify the interrupt control bit and the interrupt level selection bits in the PCM-3718's control register (BASE+9) before using the interrupt routine. Writing to the A/D status register address (BASE+8) resets the PCM-3718's interrupt request and re-enables the PCM-3718's interrupt.
3. Direct Memory Access (DMA) Transfer moves the A/D data from the PCM-3718's hardware device to the PC system memory without the system CPU. DMA is very useful in high-speed data transfers, but it is complicated to operate. Before the DMA operation you must set the DMA level (JP1), the DMA enable bit control register (BASE+9) and the registers in the 8237 DMA controller. We recommend that you use the PCM-3718 driver to perform DMA operations. See Chapter 8 for more Information on the 8237 DMA controller and PCM-3718 operations.

5.6 How to Make an A/D Conversion

To perform A/D conversion, you can write all I/O port instructions directly in your program, or you can take advantage of the PCM-3718 driver. We suggest that you apply the driver functions in your program. This will make your programming job easier and improve the program performance. See the User Manual of the software driver for more information.

Do the following to perform software trigger and program controlled data transfer without the PCM-3718 driver:

1. Set the input range for each A/D channel.
2. Set the input channel by specifying the MUX scan range.
3. Trigger the A/D conversion by writing to the A/D low byte register (BASE+0) with any value.
4. Check for the end of the conversion by reading the A/D status register (BASE+8) INT bit.
5. Read data from the A/D converter by reading the A/D data registers (BASE+0 and BASE+1).
6. Convert the binary A/D data to an integer.

CHAPTER
6

Digital Input/Output

Chapter 6 Digital Input/Output

The PCM-3718 cards provide two 8-bit digital input/output channels. The registers at addresses BASE+3 and BASE+11 can input or latch output data. Data format for each register appears as below:

BASE+3 (read port) -DIO low byte								
Bit	D7	D6	D5	D4	D3	D2	D1	D0
Value	DIO7	DIO6	DIO5	DIO4	DIO3	DIO2	DIO1	DIO0

BASE+3 (write port) DIO low byte								
Bit	D7	D6	D5	D4	D3	D2	D1	D0
Value	DIO7	DIO6	DIO5	DIO4	DIO3	DIO2	DIO1	DIO0

BASE+11 (read port) - DIO high byte								
Bit	D7	D6	D5	D4	D3	D2	D1	D0
Value	DIO15	DIO14	DIO13	DIO12	DIO11	DIO10	DIO9	DIO8

BASE+11 (write port) - DIO high byte								
Bit	D7	D6	D5	D4	D3	D2	D1	D0
Value	DIO15	DIO14	DIO13	DIO12	DIO11	DIO10	DIO9	DIO8

Using the PCM-3718's input and output functions is fairly straightforward. Page 23 shows some ideas for digital signal connections.

CHAPTER
7

Programmable Pacer

Chapter 7 Programmable Pacer

7.1 The Intel 8254

The PCM-3718 cards use the Intel 8254 programmable interval timer/counter version 2. The popular 8254 offers three independent 16-bit down counters. Each counter has a clock input, control gate and an output. You can program each counter for maximum count values from 2 to 65535.

Version 2 of the 8254 has a maximum input clock frequency of 10 MHz. The PCM-3718 provide 1 MHz and 10 MHz input frequencies to the 8254 from an onboard crystal oscillator. Jumper JP1 controls the input frequency. See page 12 for more information.

Counters 1 and 2 on the 8254 are cascaded and operated in a fixed divider configuration. Counter 1 input is connected to the 1 MHz or 10 MHz clock frequency, and the output of Counter 1 is connected to the input of Counter 2. The output of Counter 2 is internally configured to provide trigger pulses to the A/D converter, as shown below:

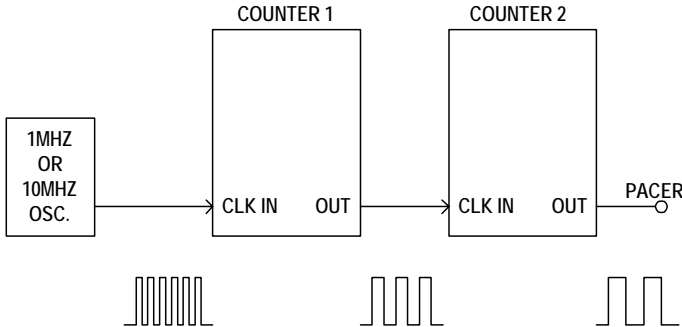

Intel 8254 has six operational modes, from Mode 0 through Mode 5. To generate a pacer clock, program both Counter 1 and Counter 2 for Mode 3 (square wave generation).

7.2 Counter Read/write and Control Register

The 8254 programmable interval timer uses four registers at addresses BASE+12, BASE+13, BASE+14 and BASE+15. Register functions are listed below:

Register	Function
BASE+12	Counter 0 read/write
BASE+13	Counter 1 read/write
BASE+14	Counter 2 read/write
BASE+15	Counter control word

Since the 8254 counter uses a 16-bit structure, each section of read/write data is split into a least significant byte (LSB) and most significant byte (MSB). To avoid errors it is important that you make read/write operations in pairs and keep track of the byte order.

The data format for the control register appears below:

BASE+15 - 8254 control, standard mode								
Bit	D7	D6	D5	D4	D3	D2	D1	D0
Value	SC1	SC0	RW1	RW0	M2	M1	M0	BCD

SC1 & SC0 Select counter

Counter	SC1	SC0
0	0	0
1	0	1
2	1	0
Read-back command	1	1

RW1 & RW0 Select read/write operation

Operation	RW1	RW0
Counter latch	0	0
Read/write LSB	0	1
Read/write MSB	1	0
Read/write LSB first, then MSB	1	1

M2, M1 & M0 Select operating mode

M2	M1	M0	Mode	Description
0	0	0	0	Programmable one shot
0	0	1	1	Programmable one shot
X	1	0	2	Rate generator
X	1	1	3	Square wave rate generator
1	0	0	4	Software triggered strobe
1	0	1	5	Hardware triggered strobe

BCD Select binary or BCD counting

BCD	Type
0	Binary counting 16-bits
1	Binary coded decimal (BCD) counting

If you set the module for binary counting, the count can be any number from 0 up to 65535. If you set it for BCD (Binary Coded Decimal) counting, the count can be any number from 0 to 9999.

If you set both SC1 and SC0 bits to 1, the counter control register is in read-back command mode. The control register data format becomes:

BASE+15 - 8254 control, read-back mode								
Bit	D7	D6	D5	D4	D3	D2	D1	D0
Value	1	1	CNT	STA	C2	C1	C0	X

CNT = 0 Latch count of selected counter(s).

STA = 0 Latch status of selected counter(s).

C2, C1 & C0 Select counter for a read-back operation.

C2 = 1 select Counter 2

C1 = 1 select Counter 1

C0 = 1 select Counter 0

If you set both SC1 and SC0 to 1 and STA to 0, the register selected by C2 to C0 contains a byte which shows the status of the counter. The data format of the counter read/write register then becomes:

BASE+12/13/14 - status read-back mode								
Bit	D7	D6	D5	D4	D3	D2	D1	D0
Value	OUT	NC	RW1	RW0	M2	M1	M0	BCD

OUT Current status of counter output

NC Null count is 1 when the last count written to the counter register has been loaded into the counting element

The pacer enable register, located at address BASE+10, has a close relationship with the counter operation. Refer to pages 32~33, Pacer Enable Register, for the register data format. The TC0 bit enables and disables the pacer. If TC0 is 0, the pacer is enabled. If TC0 is 1, the pacer is disabled.

7.3 Counter Operating Modes

MODE 0 - Stop on Terminal Count

The output will be initially low when you set mode 0. After you load the count into the selected count register, the output will remain low and the counter will count. When the counter reaches the terminal count, its output will go high and remain high until you reload it with the mode or a new count value. The counter continues to decrement after it reaches the terminal count. Rewriting a counter register during counting has the following results:

1. Writing to the first byte stops the current counting.
2. Writing to the second byte starts the new count.

MODE 1 - Programmable One-shot

The output is initially high. The output will go low on the count following the rising edge of the gate input. It will then go high on the terminal count. If you load a new count value while the output is low, the new value will not affect the duration of the one-shot pulse until the succeeding trigger. You can read the current count at any time without affecting the one-shot pulse. The one-shot is retriggerable, thus the output will remain low for the full count after any rising edge at the gate input.

MODE 2 - Rate Generator

The output will be low for one period of the input clock. The period from one output pulse to the next equals the number of input counts in the counter register. If you reload the counter register between output pulses, the present period will not be affected, but the subsequent period will reflect the value.

The gate input, when low, will force the output high. When the gate input goes to high, the counter will start from the initial count. You can thus use the gate input to synchronize the counter.

With this mode the output will remain high until you load the count register. You can also synchronize the output by software.

MODE 3 - Square Wave Generator

This mode is similar to Mode 2, except that the output will remain high until one half of the count has been completed (for even numbers), and will go low for the other half of the count. This is accomplished by decreasing the counter by two on the falling edge of each clock pulse. When the counter reaches the terminal count, the state of the output is changed, the counter is reloaded with the full count and the whole process is repeated.

If the count is odd and the output is high, the first clock pulse (after the count is loaded) decrements the count by 1. Subsequent clock pulses decrement the count by 2. After timeout, the output goes low and the full count is reloaded. The first clock pulse (following the reload) decrements the counter by 3. Subsequent clock pulses decrement the count by two until timeout, then the whole process is repeated. In this way, if the count is odd, the output will be high for $(N+1)/2$ counts and low for $(N-1)/2$ counts.

MODE 4 - Software Triggered Strobe

After the mode is set, the output will be high. When the count is loaded, the counter will begin counting. On terminal count, the output will go low for one input clock period, then go high again.

If you reload the count register during counting, the new count will be loaded on the next CLK pulse. The count will be inhibited while the GATE input is low.

MODE 5 - Hardware Triggered Strobe

The counter will start counting after the rising edge of the trigger input and will go low for one clock period when the terminal count is reached. The counter is retriggerable.

7.4 Counter Operations

Read/Write Operation

Before you write the initial count to each counter, you must first specify the read/write operation type, operating mode and counter type in the control byte and write the control byte to the control register (BASE+15).

Since the control byte register and all three counter read/write registers have separate addresses, and each control byte specifies the counter it applies to (set by SC1 and SC0), no instructions on the operating sequence are required. Any programming sequence following the 8254 convention is acceptable.

There are three types of counter operations: read/load LSB, read/load MSB and read/load LSB followed by MSB. It is important that you make your read/write operations in pairs and keep track of the byte order.

Counter Read-back Command

The 8254 counter read-back command lets you check the count value, programmed mode and current states of the OUT pin and Null Count flag of the selected counter(s). You write this command to the control word register. Format is as shown at the beginning of the chapter.

The read-back command can latch multiple counter output latches. Simply set the CNT bit to 0 and select the desired counter(s). This single command is functionally equivalent to multiple counter latch commands, one for each counter latched.

The read-back command can also latch status information for selected counter(s) by setting the STA bit to 0. The status must be latched to be read; the status of a counter is accessed by a read from that counter. For the counter status format please see the beginning of the chapter.

Counter Latch Operation

The 8254 supports the counter latch operation in two ways. The first way is to set bits RW1 and RW0 to 0. This setting latches the count of the selected counter in a 16-bit hold register. The second way is to perform a latch operation under the read-back command. Set bits SC1 and SC0 to 1 and CNT to 0. The latter method has the advantage of operating several counters at the same time. A subsequent read operation on the selected counter will retrieve the latched value.

7.5 Counter Applications

The 8254 programmable Interval timer/counter on your PCM-3718 interface module is a very useful device. You can program counters 1 and 2 as pacers to generate A/D conversion trigger pulses.

Setting the Pacer Rate

The following equation gives the pacer rate:

$$\text{Pacer rate} = \text{FCLK} / (\text{C1} * \text{C2})$$

FCLK is either 1 MHz or 10 MHz, as set by jumper JP1. The following steps tell you how to set the counter modes and constants:

1. Set Counter 1 to Mode 3 by writing '76h' to address BASE+15.
2. Set Counter 1's divisor constant C1 by writing to BASE+13. Constant C1 can be any 16-bit value from 2 to 65535. Because the 8254 has 8-bit registers, you should first write the low byte of C1 to BASE+13, then write the high byte of C1 to BASE+13.
3. Set Counter 2 to Mode 3 by writing 'B6h' to address BASE+15.
4. Set Counter 2's divisor constant C2 by writing to BASE+14. Constant C2 can be any 16-bit value from 2 to 65535. Because the 8254 has 8-bit registers, you should first write the low byte of C2 to BASE+14, then write the high byte of C2 to BASE+14.

Programming example

The following program (written in C) sets the pacer rate to 25 kHz. It uses FCLK of 10 MHz, C1 of 40 and C2 of 10.

Then 25 kHz = 10 MHz/(40*10).

```
OUTPORTB (BASE+3, 0x76); /* SET COUNTER 1 TO MODE 3*/  
OUTPORTB (BASE+1, 40); /* WRITE LOW BYTE OF C1*/  
OUTPORTB (BASE+1, 0); /* WRITE HIGH BYTE OF C1*/  
OUTPORTB (BASE+3, 0xB6); /* SET COUNTER 2 TO MODE 3*/  
OUTPORTB (BASE+2, 10); /*WRITE LOW BYTE OF C2*/  
OUTPORTB (BASE+2, 0); /*WRITE HIGH BYTE OF C2*/
```

CHAPTER
8

DMA Operation

Chapter 8 DMA Operation

Direct Memory Access improves system performance by allowing external devices to transfer information directly to or from the PC's memory without using the CPU. PCM-3718's DMA capability significantly improves the system performance in high-speed A/D applications.

8.1 Introduction to the 8237 DMA Controller

The 8237 DMA controller chip on the PC system board handles the DMA operation. This chip has four prioritized direct memory access channels. Channel 0 is reserved by the PC system to refresh its dynamic RAM. Channel 2 supports floppy disk operations. Channel 3 is generally used for hard disk operations. Channel 1 is not for any internal operations and is reserved for your applications.

Each channel has two associated control signals. The DMA Request Signal (DRQ) triggers a DMA operation, and the DMA Acknowledge Signal (DACK) authorizes the 8237 to start the data transfer.

The 8237 DMA chip has four operating modes (single, demand, block and cascade) and four control registers. These registers are:

1. Operation mode register (set mode of operation)
2. Address register (specify memory segment starting address)
3. Word count register (specify the number of transfers)
4. Initialization register (enable and disable DMA channels)

You must properly set all four registers before requesting the DMA operation.

8.2 Using DMA Transfer with PCM-3718 Cards

A DMA transfer is a powerful but complicated operation. Related descriptions of the DMA transfer have been covered in other paragraphs of this manual (for details please see pages 38~40). The following steps summarize how to use DMA transfer with PCM-3718 cards:

1. When you configure your hardware, check if any PC DMA channel is available (level 1 or level 3) and set the PCM-3718 card's jumper JP1 accordingly.
2. If you will be using the PCM-3718 driver for your DMA transfer programming, see the Software Drivers User Manual for more information.
3. If you choose to conduct your own DMA operation, you will need to have a solid understanding of the PC, 8237 DMA controller and the chosen PCM-3718 card. Make sure you perform the following steps in your DMA transfer:
 - a. Initialize the 8237 DMA controller register and page register.
 - b. Send DMA enable and trigger source data to the PCM-3718 card's control register (located at address BASE+9).
 - c. Set an external trigger pulse or pacer trigger rate.
 - d. Enable the trigger source to start the A/D conversion.

CHAPTER
9

Calibration

Chapter 9 Calibration

Regular calibration checks are key factors for accuracy maintenance. We provide a calibration program for DOS, CALB.EXE, in the CD-ROM shipped with your PCM-3718 card to assist you in this task.

Path: DOS\PCM\PCM3718.100

CALB.EXE makes calibration easy. It leads you through the calibration and setup procedures with a variety of prompts and graphic displays, showing you all of the correct settings and adjustments. The explanatory material in this section is brief, intended for use in conjunction with the calibration program.

To perform a satisfactory calibration, you need a 4½-digit digital multimeter and a voltage calibrator or a stable, noise-free D. C. voltage source.

9.1 VR Assignment

The five variable resistors (VRs) on the PCM-3718 board help you make accurate adjustments on all A/D. See the figure on page 5 for the VR locations on the board. The following list shows the function of each VR:

VR	Function
VR1	A/D full scale adjustment
VR2	A/D bipolar offset
VR3	A/D unipolar offset
VR4	High Gain Calibration offset (only for PCM-3718HG)
VR5	D/A full scale adjustment (only for PCM-3718HO)
VR6	D/A offset (only for PCM-3718HO)

9.2 D/A, A/D Calibration

Regular and accurate calibration procedures ensure maximal accuracy. The CALB.EXE calibration program leads you through D/A and A/D off-set and gain adjustment procedure. The basic steps are outlined below:

9.2.1 D/A Calibration Procedure

Please prepare a multimeter before you implement the D/A calibration. Connect it to D/A output (pin19 on connector P1)

D/A calibration procedures (PCM-3718HO only)

1. Press the **Down** button to select the code to 0 and adjust VR6 until the D/A voltage is 0V
2. Press **Up** button to set the code to 4095 and adjust VR5 until the D/A voltage is 5V
3. Repeat step1 and step2, adjusting VR5 and VR6 until the D/A voltage is exactly 0 V and 5 V.
4. Connect P1 pin19 as the external DC voltage source to P1 pin1 if the A/D channel is going to be calibrated.

9.2.2 A/D Calibration Procedures

Connect an external DC voltage source with value of 0.5 LSB to A/D Channel 0 (pin 1 on connector P1).

1. Adjust VR2 until the output from the card's A/D converter flickers between 0 and 1.
2. Connect an external DC voltage source with a value of 4094.5 LSB to A/D channel 0.
3. Adjust VR1 until the A/D reading flickers between 4094 and 4095
4. Repeat steps 2 to step4, adjusting VR1 and VR2
5. Select unipolar input configuration. Connect an external DC voltage source with a value of 6. 0.5 LSB to A/D channel 0. Adjust VR3 until the reading of the A/D flickers between 0 and 1.

APPENDIX
A

**Software Driver
User Note**

Appendix A Software Driver User Note

PCM-3718 cards are supported by a powerful software utility provided by Advantech. The lists below shows the functions supported by the PCM-3718 Series. (i.e., the items with the "*" mark are supported).

For complete function descriptions of the software utility please refer to the PC-LabCard software Utility User Manual.

*Func 0	Get Error Message
*Func 2	Get Driver Version Number
*Func 3	Driver Initialization
*Func 4	A/D Initialization
*Func 5	Perform A/D conversion with software data transfer
*Func 6	Perform A/D conversion with DMA data transfer
*Func 7	Get Func 6's operational status
*Func 8	Stop Func 6
*Func 9	Perform A/D conversion with interrupt data transfer
*Func 10	Get Func 9's operational status
*Func 11	Stop Func 9
Func 12	D/A Initialization PCM-3718HO only
Func 13	Perform D/A conversion with software data transfer PCM-3718HO only
Func 14	Perform D/A conversion with DMA data transfer
Func 15	Get Func 14's operational status
Func 16	Stop Func 14
Func 17	Perform D/A conversion with interrupt data transfer
Func 18	Get Func 17's operational status
Func 19	Stop Func 17
*Func 20	D/I Initialization
*Func 21	Perform digital input with software data transfer
Func 22	Perform digital input with DMA data transfer
Func 23	Get Func 22's operational status
Func 24	Stop Func 22

Func 25	Perform digital input with interrupt data transfer
Func 26	Get Func 25's operational status
Func 27	Stop Func 25
*Func 28	D/O Initialization
*Func 29	Perform digital output with software data transfer
*Func 30	Read back current digital output status
Func 31	Perform digital output with DMA data transfer
Func 32	Get Func 31's operational status
Func 33	Stop Func 31
Func 34	Perform digital output with interrupt data transfer
Func 35	Get Func 34's operational status
Func 36	Stop Func 34
Func 37	Timer initialization
Func 38	Timer interrupt enable
Func 39	Timer interrupt disable
Func 40	Frequency measurement start
Func 41	Get Func 40's operational status
Func 42	Stop Func 40
Func 43	Event count start
Func 44	Read event count
Func 45	Stop event count Func 43
Func 46	Pulse output start
Func 47	Pulse output stop
Func 48	One-shot pulse output
Func 49	Time interval measurement start
Func 50	Get Func 49's status
Func 51	Stop Func 49
*Func 96	Daughterboard A/D initialization
*Func 97	Perform daughterboard A/D conversion with software or interrupt data transfer
*Func 98	Get Func 97's status
*Func 99	Stop Func 97

- *Func 100 Block channel scan initialization
- *Func 101 Perform Block channel scan with software data transfer
- *Func 105 Perform Block channel scan with interrupt data transfer
- *Func 106 Get Func 105's status
- *Func 107 Stop Func 105